

# H1™

## LED Emergency Light



SKU	Model #
151308	JLEU15

Beyond LED Technology's Emergency Light With Dual Head is a compact and efficient lighting solution designed to provide reliable illumination during power outages. With dual high-output LED heads, it delivers bright, focused light for enhanced safety. Built with an injection-molded thermoplastic ABS housing and UL certified for quality, it's ideal for indoor emergency applications. The adjustable lamp heads allow flexible light direction to cover critical areas. Designed for easy wall or ceiling mounting, it ensures quick installation and dependable operation. Its long-lasting battery and energy-efficient LEDs make it a practical choice for commercial and residential settings.

### Product Features

- 2 Watt / 1 Watt each lamp
- 200 Lumens
- CCT 6000K
- 3.6V 1000mAh Ni-MH battery
- 90 minutes emergency operation
- 24-hour full charge cycle
- Injection-molded thermoplastic ABS housing
- Input voltage: 120–277V AC
- IP20 Rated
- UL Listed
- 5 Years Warranty on the electrical parts & housing  
3 Years Warranty on the battery



# LED Emergency Light



SKU: 151308

## Specifications

Parameter	Description	Value
General Performance	Model	JLEU15
	Mode of operation	DC
	Watt	2W / 1 Watt each lamp
	Lumens	200lm
	Colour Temperature	6000K
	Input Voltage	120-277V
	Frequency	60Hz
	Output Voltage	5.5V
	Output Power	2.0W
	Battery	3.6V 1000mAh battery
	Max Charge Current (mA)	100mA
	Max Discharge Current (mA)	750mA
	Charging Time	24H
	Emergency Run Time	90 min
	LED Type	2 pcs 1 W ultra bright LED lamps
	IP Rating	IP20
	Construction	Injection-molded thermoplastic ABS housing
	Housing Color	White
Product Material	ABS+PMMA	

LED EMERGENCY LIGHT



# H1™

## LED Emergency Light

### Dimensions

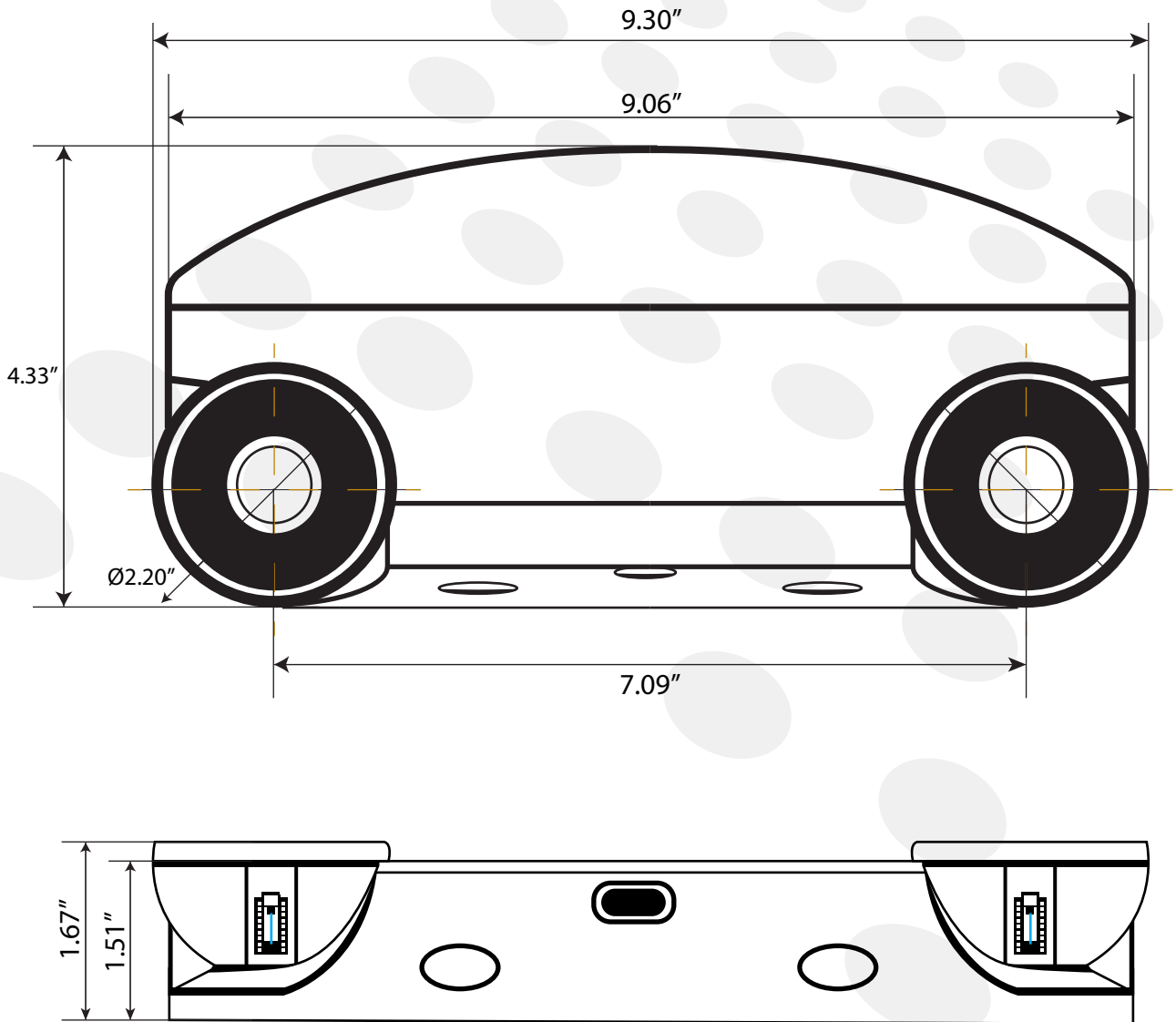



### Installation

#### INSTRUCTIONS FOR LED EMERGENCY LIGHTING FIXTURE

##### IMPORTANT:

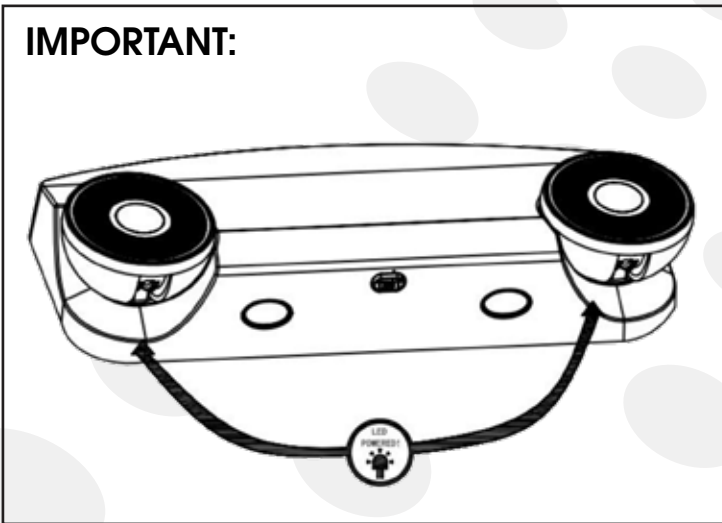

Small Battery in this unit may not be full charged. After electricity is connected to unit. Let battery charge up for at least 24 hours. Then normal operation of this unit should take effect. To check, press the "TEST" button. The light inside the unit should turn on. The lamps listed herein, when used according to these instructions with this unit equipment, are in accordance with the requirements of CSA standard C22.2 NO.141.

Install wiring to remote heads in accordance with section 46 of the Canadian electrical code, part I.

#### IMPORTANT SAFEGUARDS

When using electrical equipment, basic safety precautions should always be followed including the following:

#### READ AND FOLLOW ALL SAFETY INSTRUCTIONS

1. Do not use outdoors.
2. Equipment should be mounted in locations at heights where it will not be subject to tampering by unauthorized personnel.
3. Do not mount near gas or electric heaters.
4. The use of accessory equipment is not recommended by the manufacturer may cause an unsafe condition.
5. Do not use this equipment for other than its intended use.
6. Servicing of this equipment should be performed by qualified personnel.
7. Disconnect AC power before servicing.



# H1™

## LED Emergency Light

### Installation

#### SAVE THESE INSTRUCTIONS

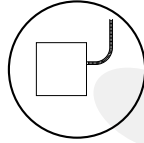
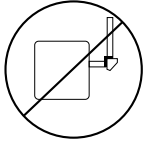

**FLEXIBLE CONDUIT ONLY**

#### INSTALLATION (J-BOX MOUNT)

1. Feed fixture leads through main bottom case and connect AC power supply (Fig A).
2. Connect wires through J-Box. Main bottom case on J-Box and secure with screws.
3. Connect battery only after continuous AC power can be provided to the unit (Fig. B).
4. Align snaps and push housing directly onto main bottom case (Fig. C). Apply continuous AC power and press TEST button to check light.

#### INSTALLATION (CONDUIT)

1. Secure main bottom case to wall surface. Route wires through hole in conduit flange and make conduit connection.
2. Connect battery only after continuous AC power can be provided to the unit (Fig. B).
3. Align snaps and push housing directly onto main bottom case (Fig. C). Apply continuous AC power and press "TEST" button to check light.

(NOTE: To appear outside blue sleeve of terminal before connecting.)

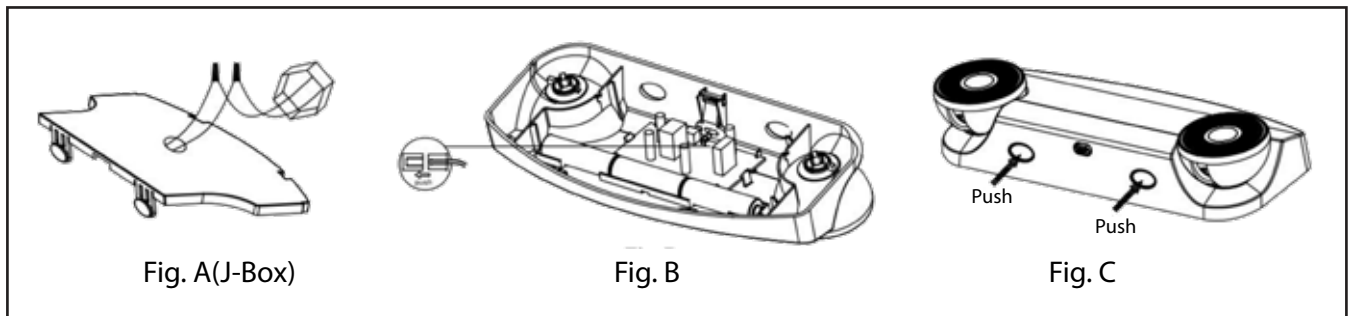



### Installation

#### WARNING:

Unused wires must be capped using enclosed wire nuts.

#### OPERATION

1. During an electrical power failure, the lamps will automatically come on for a minimum of 90 minutes.
2. To test, depress the "TEST" switch. The emergency lamps will illuminate. When the switch is released, the lamps will go off.

#### WARNING DIAGRAM:

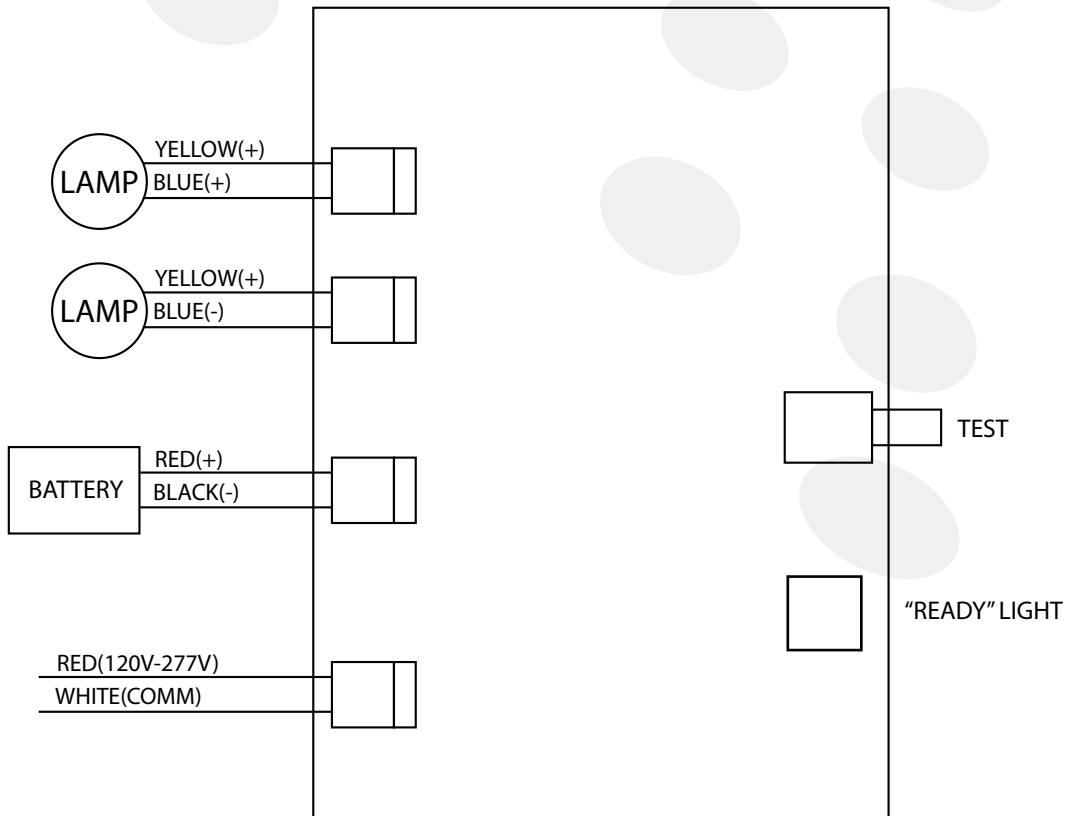



# H1™

## LED Emergency Light

### Packaging

Box Type	Box Dimension	Qty	Net Weight	Gross Weight
Inner Box	9.64" x 4.72" x 1.96"	1 Pc/Box		
Middle Box	10.03" x 5.11" x 4.33"	2 Pcs/Box		
Outer Box	14.17" x 10.63" x 11.02"	12 Pcs/Box	11.02 LBS	12.21 LBS

### Application Image



### Warranty

**5 Years Warranty on the electrical parts and housing,  
3 Years Warranty on the battery.**

**For complete warranty details,**

[Click Here.](#)