

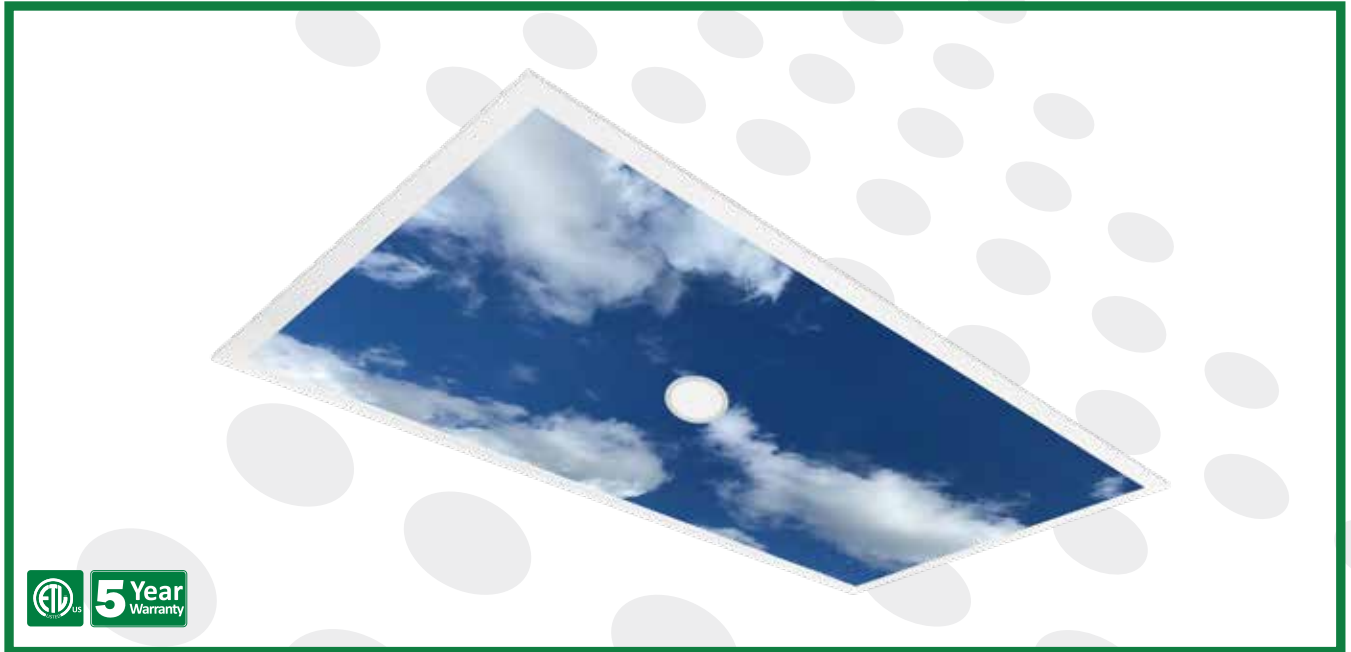

SUNGLOW™

Cloud Panel w/Downlight



CLOUD PANEL W/DOWNLIGHT

SKU	Model
157153	ZS-BL2*4-S72-3065

Beyond LED Technology’s SUNGLOW LED Cloud Panel with 4” Downlight is a unique and innovative lighting solution that combines functional illumination with a natural daylight effect. The central downlight provides focused, task-oriented lighting, while the surrounding rectangular frame emits a soft, sky-like glow that mimics natural daylight—creating the feeling of daytime even at night. Designed for both retrofit and new construction projects, this 2x4 ft panel offers adjustable wattage and CCT for optimal flexibility across different spaces. Its backlit design ensures uniform brightness, enhanced efficiency, and a visually comfortable lighting experience. Perfect for warehouses, offices, hospitals, retail spaces, and other commercial environments, the SUNGLOW Cloud Panel with Downlight brings together practicality and ambiance in one sleek fixture. With multiple mounting options—recessed, suspended, or surface—it delivers reliable performance and a modern aesthetic that enhances any interior.

Product Features

- Up to 130 lm/W
- Adjustable wattage
- Adjustable CCT
- 0-10V Dimmable
- 120° Beam Angle
- Super slim, durable design
- Built-in earthquake clips
- Input Voltage 100-277VAC
- ETL listed
- 5-year warranty

SUNGLOW™

Cloud Panel w/Downlight



SKU	ADJ. WATT	MAX LUMENS	ADJ. CCT	INPUT VOLTAGE	CRI	SIZE	LIGHT SPREAD	CONSTRUCTION	DIMMING	CERTIFICATIONS
157153	30W/40W/50W/60W/72W	9360	3K/3500K/4K/5K/6500K	100-277V	>80	2x4	120°	Metal	0-10V	ETL

Downlight

WATT	MAX LUMENS	ADJ. CCT	CRI	SIZE	LIGHT SPREAD	LENS
9W	830	3K/3500K/4K/5K/6500K	>80	4"	120°	PS Diffuser

SKU: 157153 / 2 x 4 Specifications

Parameter	Description	Value
General Performance	Model #	ZS-BL2*4-S72-3065
	Adjustable Watt	30W/40W/50W/60W/72W
	Max Lumen	9360
	Lumen Efficacy	130 lm/W
	Color Temperature	3000K/3500K/4000K/5000K/6500K
	CRI (Ra)	>80
	Light Spread	120°
	Diffuser Type	PS
Electrical	Input Voltage	100V-277V
	Frequency	50-60Hz
	Dimming	0-10V
	Power Factor	>0.95
	Flicker Percent	<8%
	THD	<10%
Physical	Operating Temperature	-20°C to 35°C
	Operating Humidity	20%-85%RH
	Storage Temperature	-20°C ~ 40°C
	Storage Humidity	20%-60%RH
	LED Brand	San'an
	LED Type	SMD2835
	LED Qty.	180 Pcs+90 Pcs
	Construction	Drop Ceiling Fixture
Qualification	Housing Color	White
	IP Rating	IP20
	Warranty	5 Years

CLOUD PANEL W/DOWNLIGHT



SUNGLOW™

Cloud Panel w/Downlight

Correlated Color Temperature (CCT)

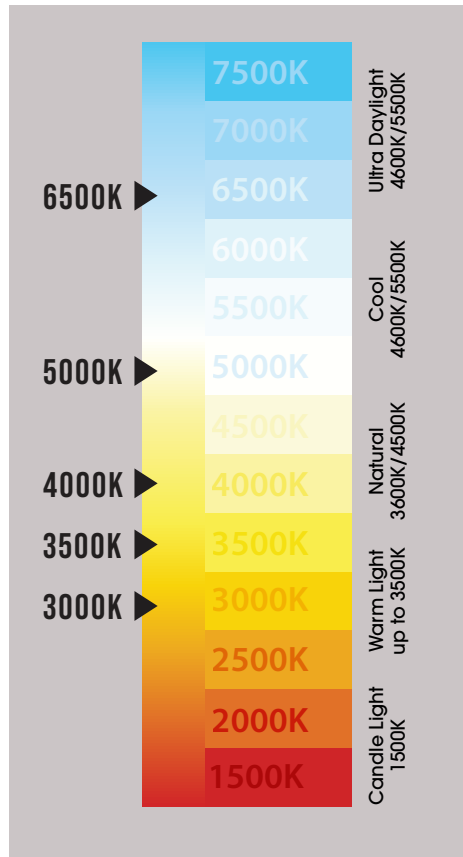

Dimensions

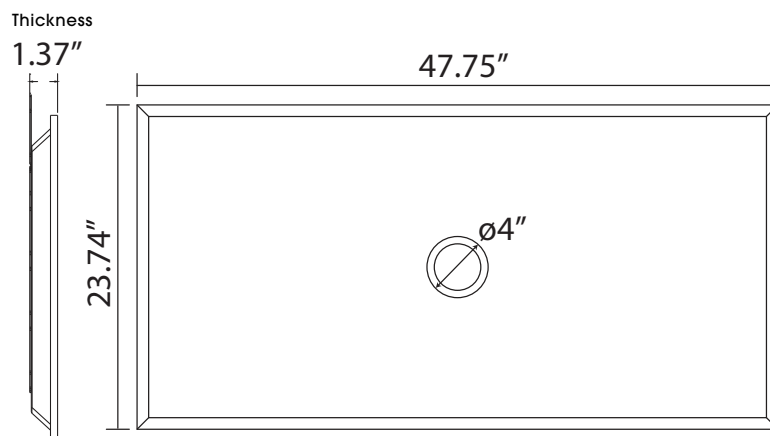

SUNGLOW™

Cloud Panel w/Downlight



Installation

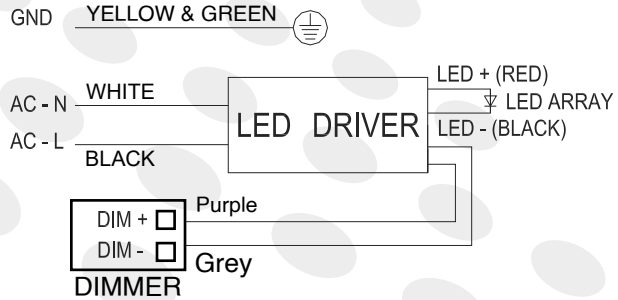
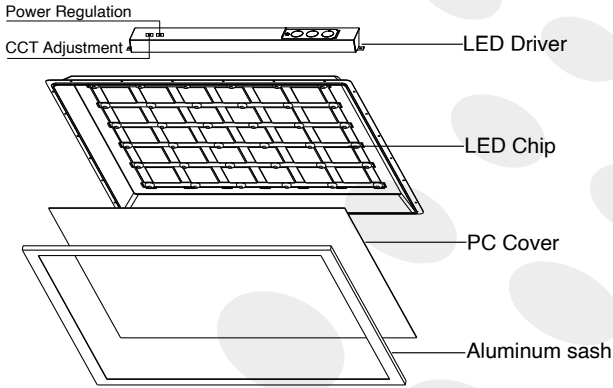

Electric Shock Attention

Ensure the power supply has been cut off before connecting the wire, and all wiring and installation of this product are required to be operated by professionals.

INSTALLATION INSTRUCTION

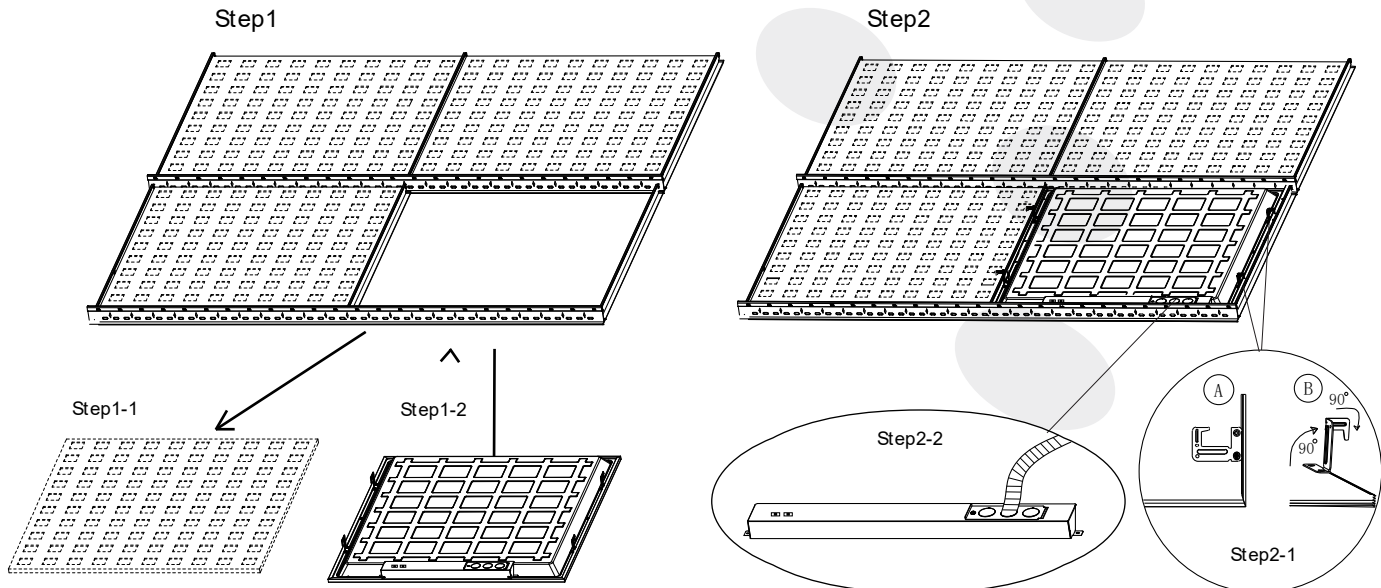

CLOUD PANEL W/DOWNLIGHT



SUNGLOW™

Cloud Panel w/Downlight

Installation

- Step 1:** Make sure of all the power is off before installing. Remove the one ceiling tile that you need to install light fixture on. Then place the light fixture on the T-bar carefully and make sure it is correctly in place and secure.
- Step 2:** Lift the 4 buckles on the back of the panel up by 90° then bend the top part of the buckles 90° towards the direction where you can anchor the light fixture to the T-bar.
- Step 3:** Place the driver on top of the lighting fixture in the back. Connect the cable between the driver and the lighting fixture. Open the driver's junction box and connect the AC wire to the driver correctly (L=black & N=white)

WARNING:

1. Please read the instructions carefully before installation.
2. Please make sure the power is off before installation.
3. The installation can only be done by certified electricians.
4. Product rated voltage is 100-277Volts. Please make sure voltage range meets the requirements
5. Please don't use chemicals to clean the lighting surface.

SUNGLOW™

Cloud Panel w/Downlight



Packaging

SKU	Panel Size	Qty.	Box Dimensions	Net Weight	Gross Weight
157153	2 X 4	2 Pcs/Box	49.60" x 3.14" x 25.59"	18.7 LBS	20.9 LBS

Application Image



CLOUD PANEL W/DOWNLIGHT



SUNGLOW™

Cloud Panel w/Downlight

Application Image



Warranty

This product is covered under a 5-year warranty. For complete warranty details, [Click Here.](#)