



GLOW PATH - PINNACLE

ARCHITECTURAL LED BOLLARD



Pinnacle Architectural LED Bollard features a sleek flat open-frame design head suited for modern outdoor environments. It includes field-selectable wattage and adjustable CCT for flexibility across lighting needs. With strong lumen output and Type V distribution, it provides uniform illumination across walkways and open areas. Constructed from die-cast aluminum with a bronze finish, it is rated IP65 and IK08 for durability. An integrated photocell enables automatic dusk-to-dawn operation, reducing manual control. Suitable for pathways, entrances, driveways, and commercial landscaping requiring consistent lighting.

PRODUCT FEATURES

- Field-Selectable Wattage 14W/19W/24W
- Adjustable CCT: 3000K / 4000K / 5000K
- Integrated Photocell with ON/OFF Switch
- Available in 39.2 Inches
- 0–10V Dimming
- Type V Distribution
- Up to 120 lm/W
- IP65 Rated
- IK08 Impact Rated
- Die-Cast Aluminum Construction
- Bronze Finish
- Anchor Bolt Mounting
- 5-Year Warranty

CONTROLS & ACCESSORIES

- Integrated Photocell (Switchable ON/OFF)
- 180° Spill Shield (Select Models)
- Retrofit Mounting Plate

APPLICATIONS

- Walkways
- Pathways
- Entrance Areas
- Driveways
- Hospitality Properties
- Commercial Landscaping
- Residential Communities
- Parks & Campuses
- Office Complexes

ELECTRICAL SPECIFICATIONS

- Input Voltage: 120–277VAC
- Power Factor: ≥ 0.90
- THD: $< 20\%$
- CRI: > 70
- Dimming: 0–10V
- Surge Protection: 4KV Standard
- Operating Temperature: $(-40^{\circ}\text{C to } +50^{\circ}\text{C})$
- Factory Default: Highest Wattage / Highest CCT / Photocell ON

MECHANICAL SPECIFICATIONS

- Housing: Die-Cast Aluminum
- Lens: UV-Stabilized Polycarbonate
- Finish: Bronze
- IP Rating: IP65
- Impact Rating: IK08
- Mounting: Anchor Bolt Installation

GLOW PATH - PINNACLE

ARCHITECTURAL LED BOLLARD



WHY DISTRIBUTORS CHOOSE GLOW PATH

- Field-Adjustable Wattage & CCT Simplify Stocking
- Photocell Built-In (No Additional SKU Required)
- DLC Eligible Models
- Architectural Appeal for Premium Projects
- Lower Shipping Volume with Modular Design
- Faster Project Quoting & Fulfillment

CERTIFICATIONS & COMPLIANCE

- UL Listed
- DLC Qualified
- IP65 Rated
- IK08 Rated

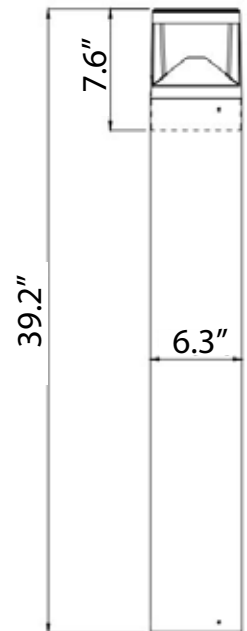

LED BOLLARD

QUICK SPEC TABLE

SKU	MODE HEAD	MODEL NUMBER	ADJ. WATT	MAX LUMENS	ADJ. CCT	INPUT VOLTAGE	CRI	SIZE	DISTRIBUTION PATTERN	CONSTRUCTION	DIMMING	IP RATING
157258	PINNACLE	BR06G-24L-S2D3C3	14W/19W/24W	2880	3K/4K/5K	120-277V	>70	39.2"	Type V	Die-cast Aluminum	0-10V	IP65



GLOW PATH - PINNACLE

ARCHITECTURAL LED BOLLARD

Photometric Data

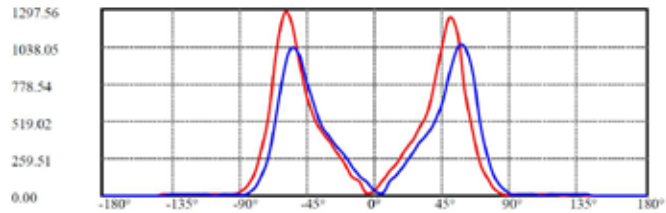
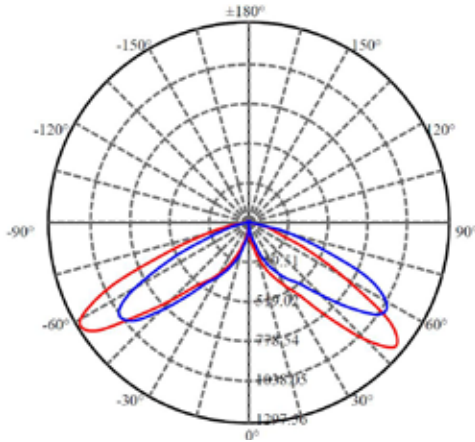

C0/C180: ——— (red line)
C90/C270: ——— (blue line)
Field angle(10%Imax):C0/180Left:145.7 Right:139.1
:C90/270Left:141.9 Right:143.7
Beam Angle(50%Imax):C0/180Left:89.7 Right:83.5
:C90/270Left:84.1 Right:88.9

Installation

IMPORTANT SAFETY INFORMATION

- Disconnect power before installing or servicing fixture
- Installation must be performed by a qualified electrician
- Verify supply voltage matches fixture rating
- Ensure proper grounding to prevent electrical shock
- Do not install in wet conditions or during rain
- Maintain IP65 seal integrity after installation
- Do not modify fixture or internal components
- Follow all national and local electrical codes
- Failure to follow instructions may result in injury or property damage

GENERAL INSTALLATION NOTES

- Suitable for outdoor use
- Do not energize fixture until all wiring connections are secured
- Do not use portable generators for fixture testing
- Inspect fixture for damage before installation
- Ensure mounting surface is structurally secure

WIRING INSTRUCTIONS

Line Connections

- LINE (L) - Black
- NEUTRAL (N) - White
- GROUND (G) - Green

0-10V Dimming Leads

- Purple – Dim (+)
- Pink / Gray – Dim (-)

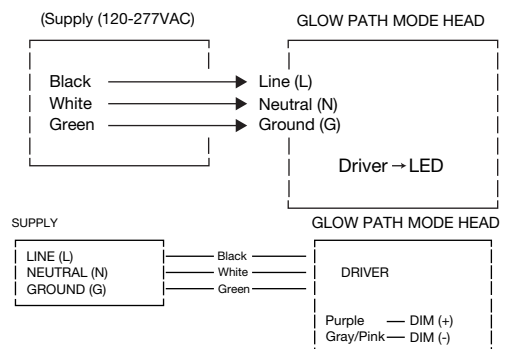

GLOW PATH - PINNACLE

ARCHITECTURAL LED BOLLARD



Installation

FIELD ADJUSTMENT (WATTAGE / CCT / PHOTOCELL)

- Open access panel
- Locate selector switches
- Set desired wattage (14W / 19W / 24W)
- Set desired CCT (3000K / 4000K / 5000K)
- Toggle photocell ON or OFF as required
- Close panel securely before energizing
- Factory default: Highest wattage / Highest CCT / Photocell ON

BUILT-IN PHOTOCELL

- Auto ON at dusk
- Auto OFF at dawn
- Wall switch must remain ON for photocell function

MOUNTING BOLLARD POLE INSTALLATION

- Install anchor bolts into concrete foundation
- Pull supply wires through center conduit opening
- Secure bollard housing onto anchor bolts
- Tighten mounting nuts evenly to ensure stability
- Ensure bollard is plumb before final tightening

FINAL CHECK

- Confirm all connections are secure
- Verify voltage
- Ensure adjustment plug is tightened
- Energize circuit
- Confirm proper operation

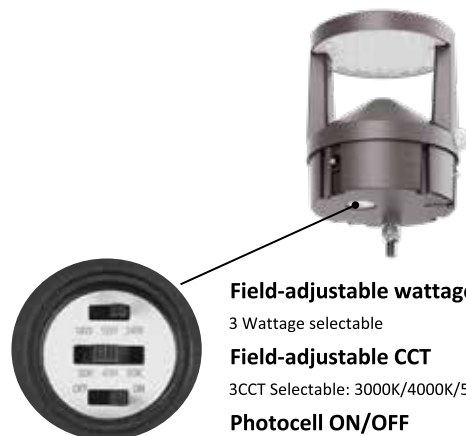

Field-adjustable wattage

3 Wattage selectable

Field-adjustable CCT

3CCT Selectable: 3000K/4000K/5000K

Photocell ON/OFF

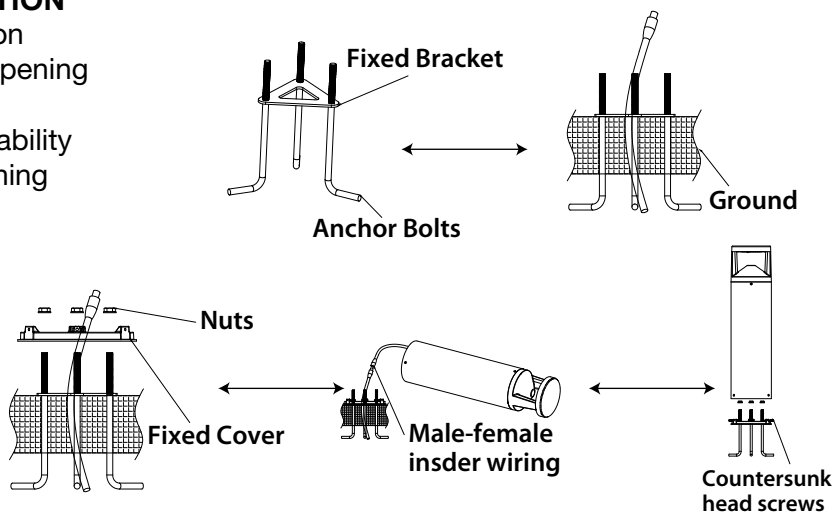

Packaging

SKU	Box Dimension	Qty	Net Weight	Gross Weight
157258	8.29" x 8.29" x 10.79"	1 PC/Box	3.5 LBS	4.2 LBS
157262	36.34" x 8.27" x 8.39"	1 PC/Box	6.8 LBS	9.5 LBS

Warranty

- 5 Years warranty

<https://beyondledtechnology.com/pages/terms-and-conditions>