

LED Linear Pendant

LP70130

INSTALLATION SHEET

START FROM HERE

- Make sure power is completely off at the fuse box.
- Have your fixture installed by a qualified licensed electrician
- Prepare everything in a clear area.
- Wear gloves at all times during this installation.
- Read instructions carefully before you start assembly.
- Keep this instruction sheet for future reference.

Please Note:

- All Kuzco LED fixture comes with pre-wired LED module(s).
- Unless instructed to do so, please do not touch any part of the LED module(s) as any unnecessary contact with the module could cause permanent damage.
- For dimming, an ELV (Electronic Low Voltage) or TRIAC type of dimmer is required.

Technical Support: 1-855-855-8926

1. Remove fixture from its original package
2. Remove mounting plate (1c) from canopy (2a)
3. Attach mounting plate (1c) to electrical junction box (1a) using screws provided (1d) in hardware package
4. Make proper electrical connections (black to hot "l", white to neutral "n", ground to "gnd") with wire nuts (1b) provided in hardware package
5. Attach canopy (2a) to mounting plate (1c) with canopy screws (2c) using allen key (2d) provided
6. Locate and install ceiling anchor (3b) using expansion bolt (3a) supplied, adjust wire length from canopy to anchor and fixture hanging height, by pressing wire grippers (2b) on side of canopy
7. Make electrical connection to fixture body (4a) by connect coaxial connector (3d), and then secure with decorative connector (3c)

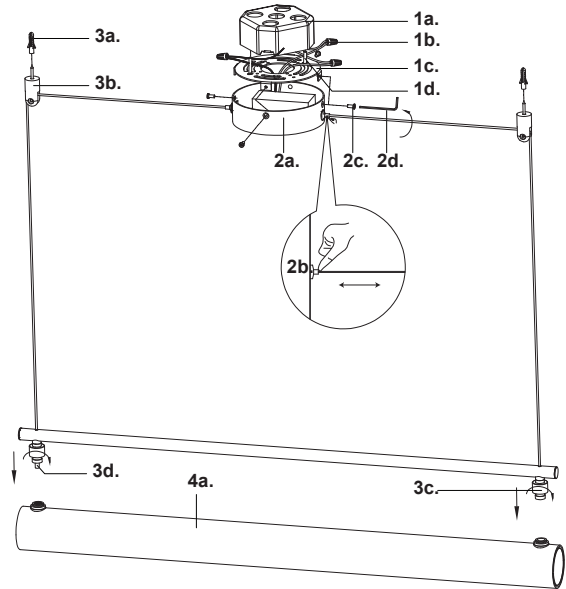

For Alternative Side Canopy Install

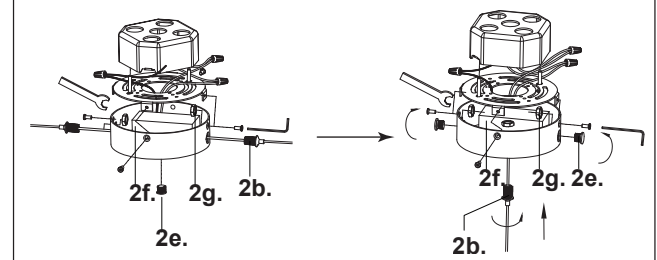

For alternative side canopy install

1. Disconnect output wires on driver (2f)
2. Move wire gripper (2b) to bottom of the canopy, secure with nut (2g), and close holes on side of canopy with plugs (2e)
3. Reconnect driver positive wire to center core of hanging cable, and negative to meshed conductor
4. Ceiling anchor with gripper (2b) with non-conductive cable mount to ceiling with expansion bolt (3a), cover with decorative barrel (3e)

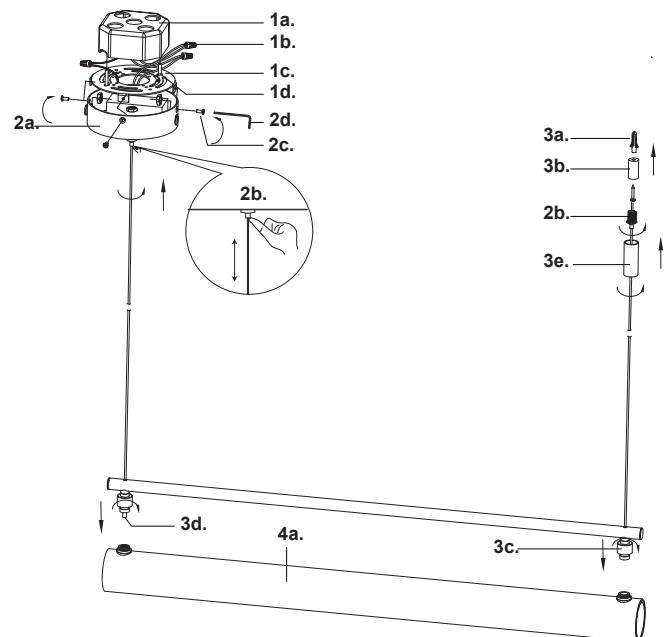

KUZCO

19054 28th Avenue Surrey, BC Canada V3Z 6M3
 T: 604 538 7162 TF: 1-855 85 KUZCO F: 604 538 7196
 W: kuzcolighting.com
 20200420