

# Single Lamp LED Pendant

**PD7801**  
INSTALLATION SHEET

## START FROM HERE

- Make sure power is completely off at the fuse box.
- Have your fixture installed by a qualified licensed electrician
- Prepare everything in a clear area.
- Wear gloves at all times during this installation.
- Read instructions carefully before you start assembly.
- Keep this instruction sheet for future reference.

**Technical Support:** 1-877-452-6858

## Please Note:

- All Kuzco LED fixtures come with pre-wired LED module(s).
- Unless instructed to do so, please do not touch any part of the LED module(s) as any unnecessary contact with the module could cause permanent damage.
- For dimming, an ELV (Electronic Low Voltage) type of dimmer is required.

- 1.** Remove the fixture from its original packaging. Next, remove the canopy mounting plate (1c) from within the canopy (2b) by removing the two decorative nuts (2c).
- 2.** Secure the mounting plate (1c) to the junction box (1a) with screws (1e). To set the fixture hanging height (120" maximum), simply push in the sleeve (2d) at the canopy where the wire comes out from. Once the sleeve is pushed in you can push the wire up to shorten, or pull the wire down to lengthen. When you have selected your desired length, just release the sleeve and the wire will be held tightly in place.
- 3.** You are now ready to mount the canopy to the mounting plate. First connect all wires (1b) correctly black to black "L", white to white "N" and the ground wire with provided marrets from the hardware package. Align the two screws (1d) hanging downward from the mounting plate (1c) to the two holes inside the canopy (2b). Push the canopy up towards the ceiling so the screws (2d) point through the holes in the canopy. Next, screw on the two decorative nuts (2c) onto the two screws (2a) pointing through the canopy, this will secure the canopy to the mounting plate.
- 4.** You have now completed the installation of your fixture, enjoy.

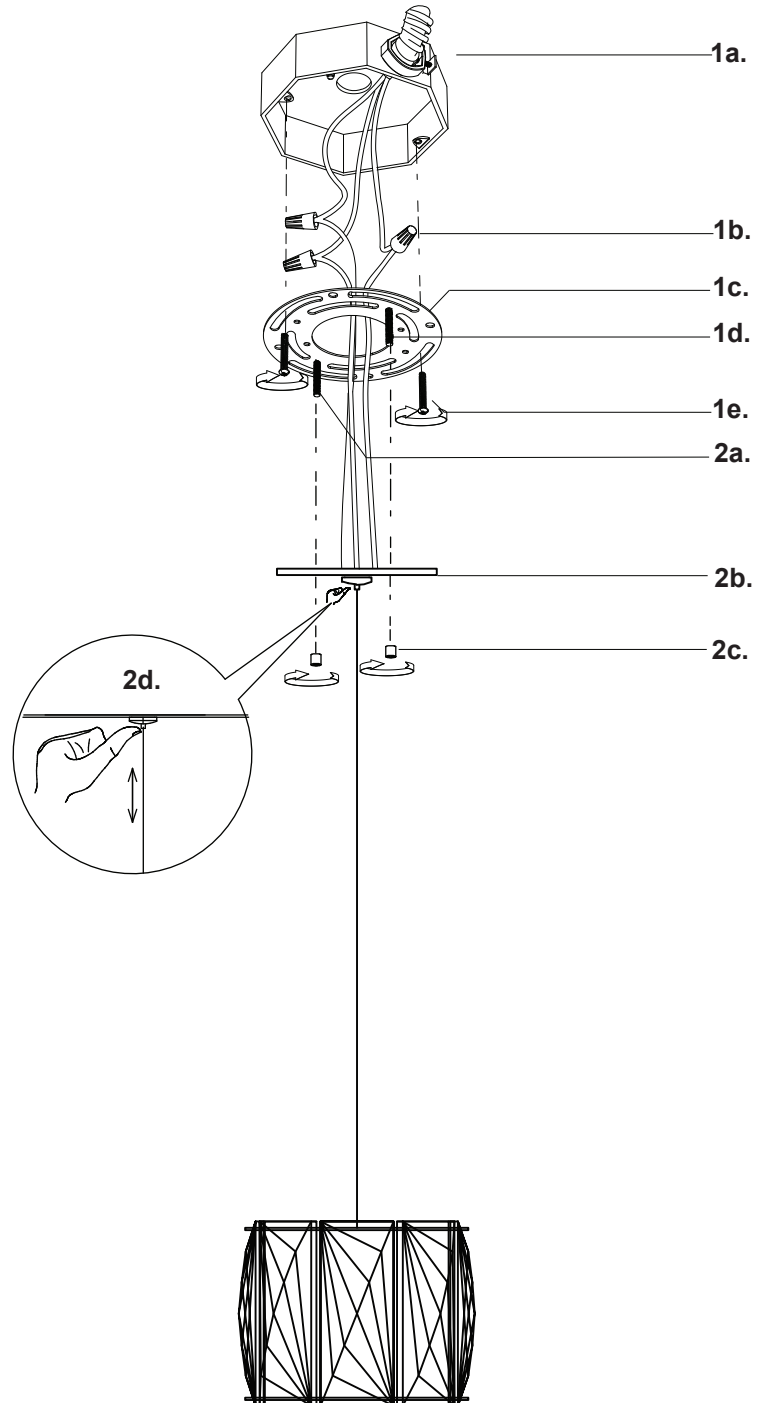

**KUZCO**  
LIGHTING

19054 28th Avenue Surrey, BC Canada V3S 6M3  
T: 604 538 7162 TF: 1-855 85 KUZCO F: 604 538 7196  
W: kuzcolighting.com  
20160426