

RP-131PIR-DH

SENSOR KIT FOR TROFFER TRANSFORMER



12V
DC POWERED



DIMMING



MOTION SENSOR

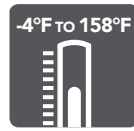

OPERATING TEMP

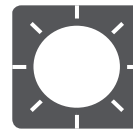

DAYLIGHT
HARVESTING

motion sensor with daylight harvesting

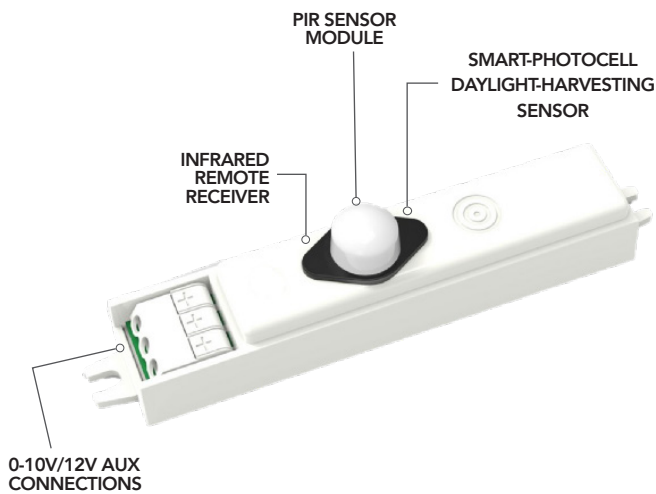

- Occupancy & daylight sensor
- Adjusts light based on occupancy and/or daylight
- Powered by 0-10V/12V AUX connections
- Passive infrared (PIR) occupancy sensor
- Works right out of the box, requires no pre-commissioning (see default settings on pg.3)
- Infrared remote control available (sold separately)
- Uses less than 0.1W in standby mode

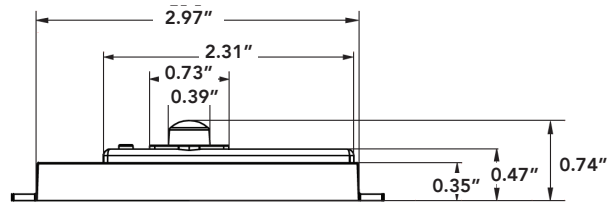
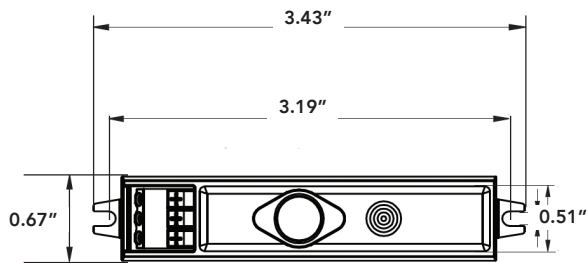

PART #	UPC	DESCRIPTION
RP-131PIR-DH	844006058654	PASSIVE INFRARED OCCUPANCY SENSOR

RemPhos by Light Efficient Design
lighting on target

LIGHT EFFICIENT DESIGN HEADQUARTERS 188 S. Northwest Highway • Cary, IL 60013
INNOVATION & MANUFACTURING CENTER 30 Log Bridge Road, Building 200 • Middleton, MA 01949
847.380.3540 • led-llc.com



Remote Control Settings

If satisfied with default settings, remote control is not needed. If settings need to be changed, optional remote control (RP-OC2-REMOTE-IR11), is required.



PERMANENT ON FUNCTION

Microwave signal disabled

Press 'ON' button, fixture goes to permanent on mode, sensor is disabled. With memory function against power failure.

* Press 'Auto' or 'Reset' to quit this mode.



PERMANENT OFF FUNCTION

Microwave signal disabled

Press 'OFF' button, fixture goes to permanent off mode, sensor is disabled.

With memory function against power failure

* Press 'Auto' or 'Reset' learn' to quit this mode.



SENSOR MODE

Press 'Auto' button, the sensor starts to work and all settings remain the same as the latest status before the light was switched on/off.



RESET FUNCTION

Press 'Reset' button, all settings go back to factory default settings.

FACTORY DEFAULT SETTINGS - REMOTE REQUIRED TO CHANGE SETTINGS

Daylight sensor=disable

Hold time=5min

Twilight time=+∞

Twilight level=30%

NOTE daylight harvest function is disabled in factory default mode. Choose the appropriate lux threshold first to activate the daylight harvest function.



DISABLE DAYLIGHT SENSOR

Press 'Disable' button, the daylight sensor will be disabled, the motion sensor will work always, even in daytime.



TEST MODE

Test mode' is used for testing purpose only, for users to check the the detection range.

**Quit test mode by pressing any other button of 'Hold time'. The sensor settings are changed accordingly.

TEST MODE SETTINGS

Daylight sensor=disable

Hold time=3s

Twilight time=N/A

Twilight level=N/A



Sensitivity section not used

IR11

- The light will blink (~0.5s) ONCE when sensor successfully receives RC signal after pressing any valid button.
- When "twilight level" set at 0%, it becomes ON/OFF control.

—○ Easy operation for daylight harvesting dimming function

Utilizing the smart photocell technology, this sensor can tell the difference between natural light and LED light from behind the fixture lens, switching on automatically (even without movements) when the ambient light is below target value, and then switch off automatically whenever the artificial light is not required (ambient light is bright enough). This special daylight sensor responds only to changes of natural light, any artificial light has no influence on its readings.

STEP 1

Choose the desired daylight sensor threshold, the daylight sensor will automatically switch on when surrounding brightness is below the chosen threshold. If surrounding brightness is above the threshold, daylight sensor will turn fixture off.

STEP 2

During operation, the daylight sensor regulates the light output automatically according to the level of surrounding brightness.



STEP 3

The daylight sensor will automatically switch the fixture off when the natural light is confirmed sufficient (lux-off sampling time is 30s).

NOTE

- Suggested setting for the daylight harvest level is 300 lux, this value should suit most of general applications.
- Lux-Off sampling time–30s; Lux-On sampling time–10s.
- Lux-On function takes effect without motion only when standby dimming period set at $+\infty$.

RP-131PIR-DH

SENSOR KIT FOR TROFFER TRANSFORMER



— Sensor spacing and detection range

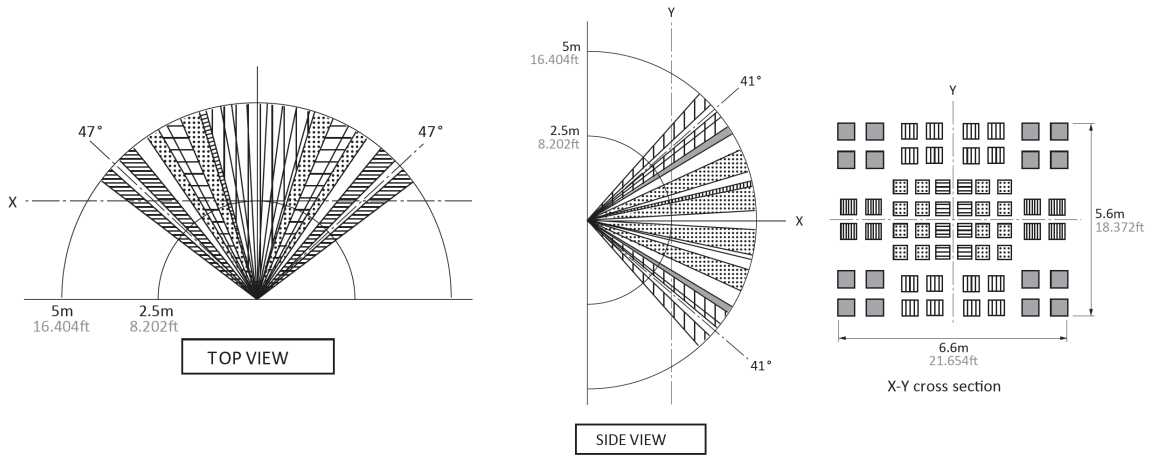

— Wiring Diagram

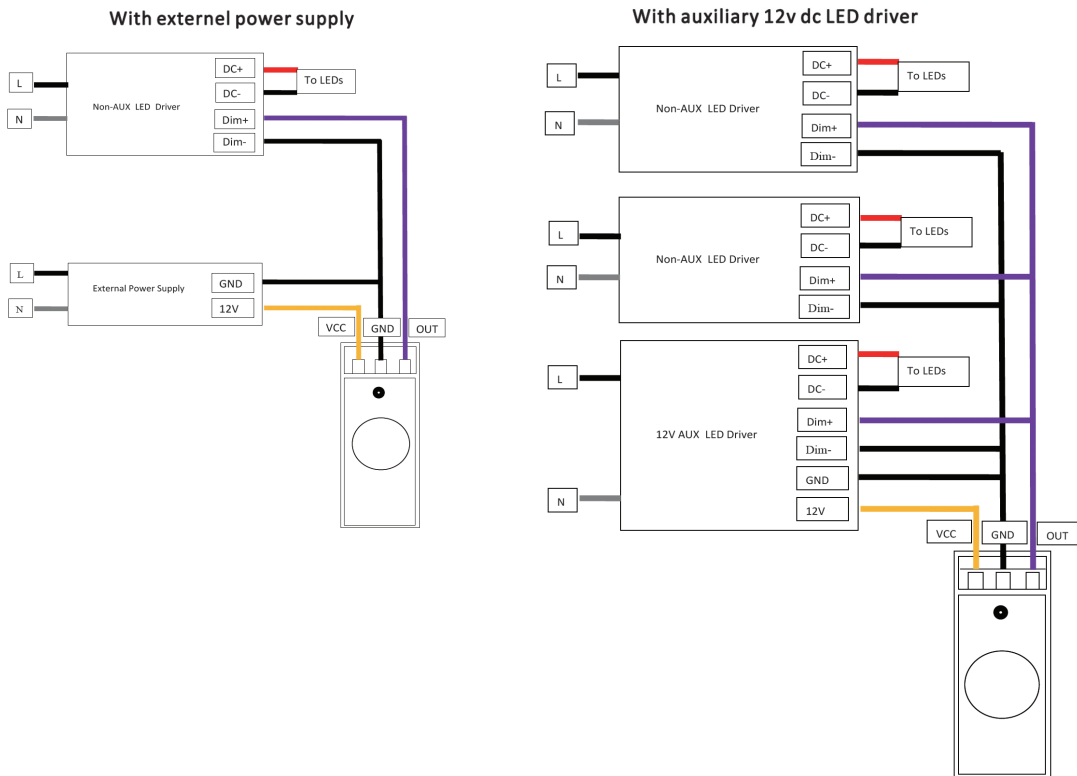

REVISION HISTORY	
-	FIRST GENERATION PRODUCT

RemPhos by Light Efficient Design
lighting on target

LIGHT EFFICIENT DESIGN HEADQUARTERS 188 S. Northwest Highway • Cary, IL 60013
INNOVATION & MANUFACTURING CENTER 30 Log Bridge Road, Building 200 • Middleton, MA 01949
847.380.3540 • led-llc.com

10.20.20 Information is subject to change without notice.